



LAMINA
TECHNOLOGIES

NEW PRODUCT HIGHLIGHTS

SUMMER 2016



HIGH FEED MILLING Introducing SDKW for High Feed | **T-SLOTTING** New T-Slotting Cutters | **90° SHOULDER MILLING** Introducing APKT 060204 | **SOLID CARBIDE END MILLS** Addition of 90° 4 Flute with Corner Radius to our End Mill Line

HIGH FEED MILLING

SDKW 0904-HF | SDKW 1205-HF

LT 3000



CUTTER RANGE

SDKW 0904-HF



BOOST PRODUCTIVITY.

Lamina Technologies introduces our NEW SDKW high feed insert with reinforced geometry for material groups P, K and H.

S D K W



Shape

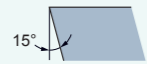

Clearance Angle

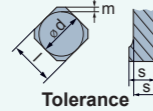

Tolerance
 $d \pm 0.08$
 $m \pm 0.013$
 $s \pm 0.025$

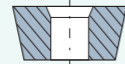

Fixing,
Chipbreaker

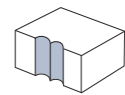

plunging

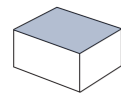

face
milling

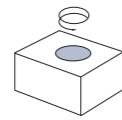

helical
interpolation

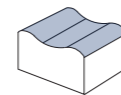

copying

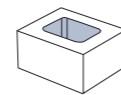

pocket
milling

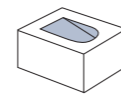

ramping
down

DESIGNATION	L	S	R _{prog.}	DIRECTION	CATALOG #
SDKW 0904-HF LT 3000	9.52	4.76	2.0	Neutral	M0004263
SDKW 1205-HF LT 3000	12.70	5.56	2.5	Neutral	M0004224

FEATURES

- Specially developed for K, P and H material groups
- Stronger cutting edge, reliable geometry
- Predictable wear
- Maximum productivity increase due to high metal removal rate per cutting edge

Check our SDKX positive insert for high feed. Suitable for universal machining, particularly soft and exotic materials.

MULTI-MAT™

magia

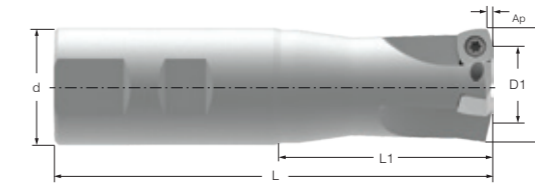

END MILLS

DESIGNATION	D	D1	d	L	L1	Ap	Z	α Ramp*	CATALOG #
LT 902 WL-W-D025/2	25	9.6	25	200	60	1.5	2	3.5	M2003350
LT 902 W-W-D025/2	25	9.6	25	120	60	1.5	2	3.5	M2003351
LT 902 WL-W-D032/3	32	16.6	32	200	60	1.5	3	2.0	M2003352
LT 902 W-W-D032/3	32	16.6	32	120	60	1.5	3	2.0	M2003353

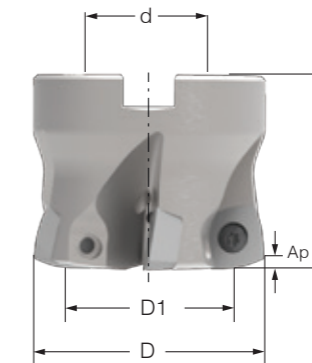

SHELL MILLS

DESIGNATION	D	D1	d	L	Ap	Z	α Ramp*	CATALOG #
LT 902 M-W-D040/5	40	24.6	16	40	1.5	5	0.8	M2003341
LT 902 M-W-D042/5	42	26.6	16	40	1.5	5	0.8	M2003342
LT 902 M-W-D050/6	50	34.6	22	40	1.5	6	0.7	M2003343
LT 902 M-W-D052/6	52	36.6	22	40	1.5	6	0.7	M2003344
LT 902 M-W-D063/6*	63	47.6	22	40	1.5	6	0.6	M2003345
LT 902 M-W-D066/6*	66	50.6	22	40	1.5	6	0.6	M2003346

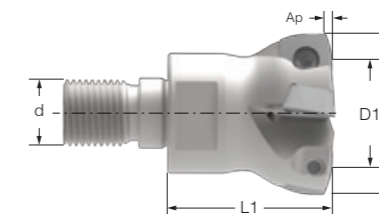

SCREW COUPLING

DESIGNATION	D	D1	d	L	Ap	Z	α Ramp*	CATALOG #
LT 902 S-W-D025/2	25	9.6	M12	35	1.5	2	3.5	M2003347
LT 902 S-W-D032/3	32	16.6	M16	35	1.5	3	2.0	M2003348
LT 902 S-W-D035/4	35	19.6	M16	35	1.5	4	1.5	M2003349

Replacement parts — Key: M2000602 Screw: M2001420

* On request

CUTTER RANGE

SDKW 1205-HF



MACHINING CONDITIONS

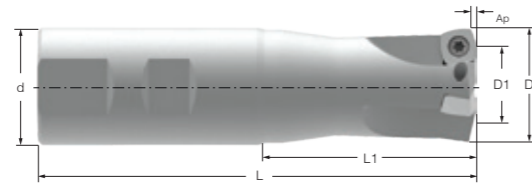

END MILLS

DESIGNATION	D	D1	d	L	L1	Ap	Z	α Ramp°	CATALOG #
LT 903 W-W-D032/2	32	11	32	120	60	2	2	2.0	M2003366
LT 903 WL-W-D032/2	32	11	32	200	60	2	2	2.0	M2003365

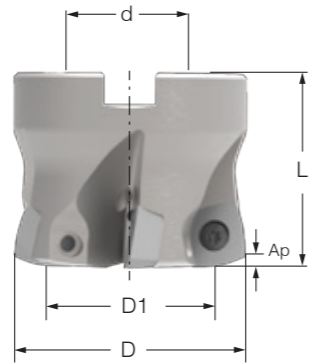

SHELL MILLS

DESIGNATION	D	D1	d	L	Ap	Z	α Ramp°	CATALOG #
LT 903 M-W-D050/4	50	29	22	40	2	4	0.8	M2003661
LT 903 M-W-D050/5	50	29	22	40	2	5	0.8	M2003357
LT 903 M-W-D052/5	52	31	22	40	2	5	0.8	M2003358
LT 903 M-W-D063/5	63	42	22	40	2	5	0.6	M2003662
LT 903 M-W-D063/6	63	42	22	40	2	6	0.6	M2003360
LT 903 M-W-D066/6	66	45	22	40	2	6	0.6	M2003361
LT 903 M-W-D080/8	80	59	27	50	2	8	0.4	M2003452

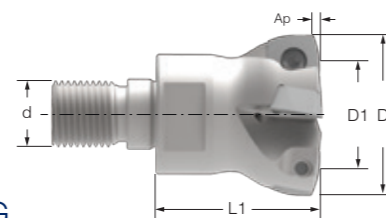

SCREW COUPLING

DESIGNATION	D	D1	d	L	Ap	Z	α Ramp°	CATALOG #
LT 903 S-W-D032/2	32	11	M16	35	2	2	2.0	M2003362
LT 903 S-W-D035/2	35	14	M16	35	2	2	1.5	M2003364
LT 903 S-W-D040/4	40	19	M16	40	2	4	0.8	M2003354
LT 903 S-W-D042/4*	42	21	M16	35	2	4	0.8	M2003356

Replacement parts — Key: M2000602 Screw: M2001420

* On request

SDKW 0904 HF – LT 3000

Material Group	Gr. N°	VDI Group	Material Examples	Hardness	D.O.C [mm]		Feed [mm/tooth]		V _c [m/min]		Suggested Starting Parameters					
					min	max	min	max	min	max	D.O.C	Feed	V _c			
Non Alloyed	1	1	C35, Ck45, 1020, 1045, 1060, 28Mn6	125 HB	0.3	1.5	0.3	1.50	190	330	1.1	1.3	250			
				190 HB						300			220			
				250 HB						250			200			
Low Alloyed	2	2	42CrMo4, S150, Ck60, 4140, 4340, 100Cr06	230 HB	0.3	1.3	0.3	1.36	150	210	0.8	1.1	180			
				280 HB					130	190			150	200		
				180 HB					150	240			130	170	1.0	140
				350 HB					130	170			130	170	1.0	140
				350 HB					130	170			130	170	1.0	140
High Alloyed	3	3	X40CrMoV5, H13, M42, D3, S6-S-2, 12Ni19	220 HB	0.3	1.3	1.20	90	150	0.7	0.9	130				
				280 HB				130	190			110	100			
				320 HB				60	110			90	80	0.7	80	
				350 HB				60	110			90	80	0.7	80	
Grey	7	7	GG20, GG40, EN-GJL-250	150 HB	0.3	1.5	0.3	2.26	240	1.2	1.3	200				
				200 HB					150			220	190	160		
				250 HB					150			220	190	160		
Malleable & Nodular	8	8	GG20, GG70, 50005	150 HB	0.3	1.5	0.3	1.36	100	1.2	1.1	180				
				200 HB					100			180	150	130		
				250 HB					100			180	150	130		
				250 HB					100			180	150	130		
Steel	11	11	X100 CrMo13, 440C, G-X260NiCr42	45 HRc	0.3	0.6	0.3	0.90	40	0.6	0.6	60				
				50 HRc				80				0.5	55			
				55 HRc				60				0.4	50			
				400 HB				80				0.4	50			
				400 HB				80				0.4	50			
Chilled Cast Iron White Cast Iron	41	41	G-X300CrMo15	55 HRc	0.3	0.6	0.5	30	60	0.4	40					
				55 HRc				30				60	0.4	40		

SDKW 1205 HF – LT 3000

Material Group	Gr. N°	VDI Group	Material Examples	Hardness	D.O.C [mm]		Feed [mm/tooth]		V _c [m/min]		Suggested Starting Parameters					
					min	max	min	max	min	max	D.O.C	Feed	V _c			
Non Alloyed	1	1	C35, Ck45, 1020, 1045, 1060, 28Mn6	125 HB	0.3	2.0	0.3	2.70	190	330	1.3	1.7	250			
				190 HB						300			220			
				250 HB						250			200			
Low Alloyed	2	2	42CrMo4, S150, Ck60, 4140, 4340, 100Cr06	230 HB	0.3	1.6	0.3	2.50	150	210	1.0	1.5	180			
				280 HB					130	190			150	200		
				180 HB					150	240			130	170	1.4	140
				350 HB					130	170			130	170	1.4	140
				350 HB					130	170			130	170	1.4	140
High Alloyed	3	3	X40CrMoV5, H13, M42, D3, S6-S-2, 12Ni19	220 HB	0.3	1.6	0.3	2.25	90	0.8	1.2	130				
				280 HB				1.3	2.00			130	120			
				320 HB				1.1	1.80			60	110	1.0	100	
				350 HB				1.1	1.60			60	110	1.0	80	
Grey	7	7	GG20, GG40, EN-GJL-250	150 HB	0.3	2.0	0.3	2.70	150	1.6	1.7	200				
				200 HB					150			220	190	160		
				250 HB					150			220	190	160		
Malleable & Nodular	8	8	GG20, GG70, 50005	150 HB	0.3	2.0	0.3	2.25	100	1.6	1.6	150				
				200 HB					100			180	150	130		
				250 HB					100			180	150	130		
				250 HB					100			180	150	130		
Steel	11	11	X100 CrMo13, 440C, G-X260NiCr42	45 HRc	0.3	0.8	0.3	1.25	40	0.7	0.8	60				
				50 HRc				0.7				1.10	70	0.5	55	
				55 HRc				0.6				0.90	60	0.4	50	
				400 HB				0.7				0.80	80	0.6	50	
				400 HB				0.7				0.80	80	0.6	50	
Chilled Cast Iron White Cast Iron	41	41	G-X300CrMo15	55 HRc	0.3	0.6	0.6	30	60	0.4	40					
				55 HRc				30				60	0.4	40		

T - SLOTTING

SPMT 06304-TN | SPMT 09T308-TN | SPMT 120408-TN

LT 3000



CUTTER RANGE



MORE VERSATILITY WITH MULTI-MAT™.

Lamina Technologies introduces t-slotting cutters with versatile SPMT indexable inserts.

S P M T

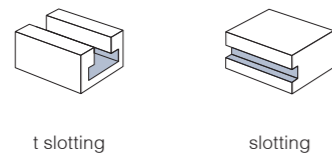
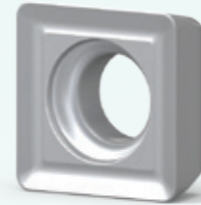
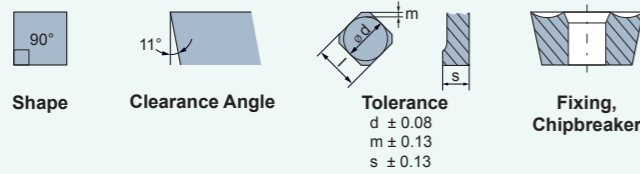

DESIGNATION	L	S	R	DIRECTION	CATALOG #
SPMT 06304-TN LT 3000	6.35	3.2	0.40	Neutral	M0003416
SPMT 09T308-TN LT 3000	9.53	3.71	0.80	Neutral	M0003417
SPMT 120408-TN LT 3000	12.70	4.80	0.80	Neutral	M0003419

FEATURES

- Soft cutting due to the positive geometry
- Internal coolant supply
- For T slot cutters according to DIN 650-UNI4788-ISO 299 norms

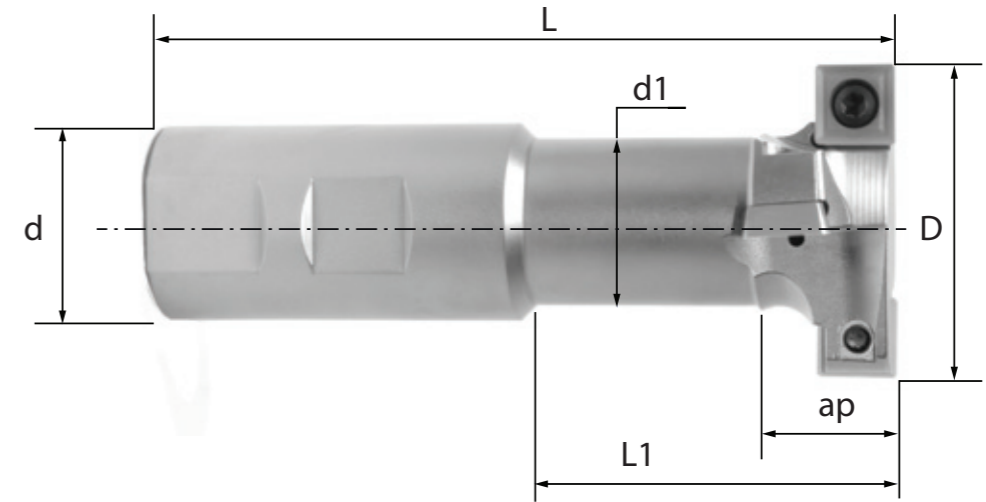

CUTTERS – SPMT 06304-TN

DESIGNATION	D	d	d1	L	L1	Ap	Z	Z _{eff}	CATALOG #
LT 400-06 W-W-D021/1	21	16	11	76	23	9	2	1	M2004218
LT 400-06 W-W-D025/2	25	16	13	82	31	11	4	2	M2004219

CUTTERS – SPMT 09T308-TN

DESIGNATION	D	d	d1	L	L1	Ap	Z	Z _{eff}	CATALOG #
LT 400-09 W-W-D032/2	32	20	17	88	38	14	4	2	M2004220
LT 400-09 W-W-D040/2	40	25	21	108	50	17	4	2	M2004221

CUTTERS – SPMT 120408-TN

DESIGNATION	D	d	d1	L	L1	Ap	Z	Z _{eff}	CATALOG #
LT 400-12 W-W-D050/2	50	32	27	120	56	22	4	2	M2004222

90° SHOULDER MILLING

APKT 060204

LT 3000



CUTTER RANGE



GOOD THINGS COMES IN SMALL PACKAGES.

Lamina Technologies introduces the NEW APKT 060204 insert available in our premium milling grade. Small but versatile.

A P K T

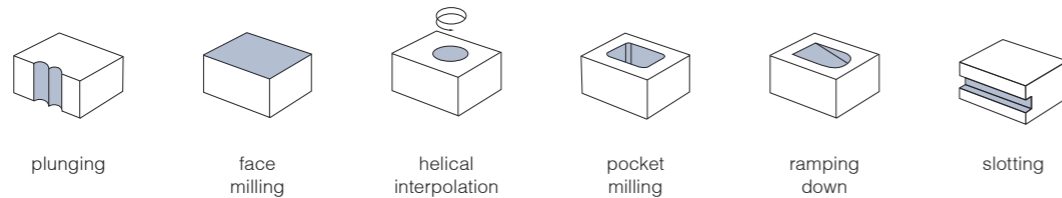
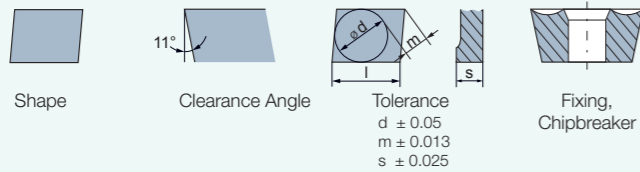

DESIGNATION	L	S	R	DIRECTION	CATALOG #
APKT 060204 PDTR LT 3000	6.00	2.16	0.40	Right	M0004026

FEATURES

- More teeth per diameter
- Increased effective feed rate
- Smooth cut with less cutting forces
- Replaces HSS solid mills, reducing costs

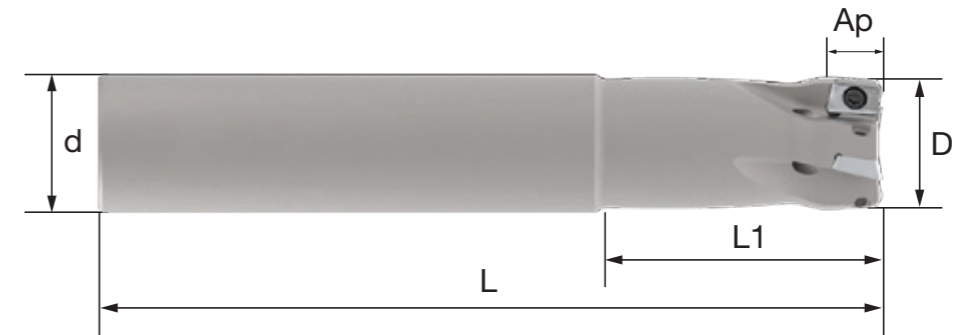

END MILLS

DESIGNATION	D	d1	L	L1	Ap	Z	α	CATALOG #
LT 751 C-W-D010/2	10	10	72	16	5.2	2	7.0	M2003066
LT 751 C-W-D012/3	12	12	80	26	5.2	3	5.0	M2003069
LT 751 CL-W-D016/3	16	16	120	50	5.2	3	2.4	M2003070
LT 751 C-W-D016/4	16	16	90	32	5.2	4	2.4	M2003071
LT 751 C-W-D020/5	20	20	100	40	5.2	5	1.6	M2003072
LT 751 C-W-D025/7*	25	20	120	40	5.2	7	1.2	M2003073
LT 751 C-W-D032/8*	32	25	130	40	5.2	8	0.8	M2003074
LT 751 C-W-D040/10*	40	32	140	40	5.2	10	0.6	M2003075

Replacement screw: M2001640
 Replacement bit (Torx Plus 6IP): M2000602
 * On request

ADVANTAGES



MACHINING CONDITIONS

COMPARED WITH LARGER INSERTS

GREATER PRODUCTIVITY

- Due to the small size of the inserts, it is possible to have more teeth than other indexable cutters of the same diameter, increasing the effective feed rate.

SOFT AND STABLE CUT

- Although the effective feed rate can be higher, the feed per tooth is lower than the feed per tooth with bigger inserts, making the cut smoother with less cutting forces. Excellent advantage for machines with relatively low power.
- Good stability by having minimum of 2 teeth, even in the smallest cutter diameter (10mm).



∅40 END MILLS CUTTER,
APKT 06 / 10 TEETH

COMPARED WITH SOLID END MILLS

INCREASED PRODUCTIVITY

- Replaces HSS solid mills in roughing to semi-finishing with much higher metal removal rate.

COST SAVINGS, MORE RELIABILITY

- Replaces carbide solid mills in roughing to semi-finishing operations, with substantial cost savings.
- No need to regrind when worn. Simply exchange the insert cutting edge.
- Less carbide is used per insert, which means more economy and less environmental impact.
- Cutter body made of steel improves resistance to shocks/instability while machining.

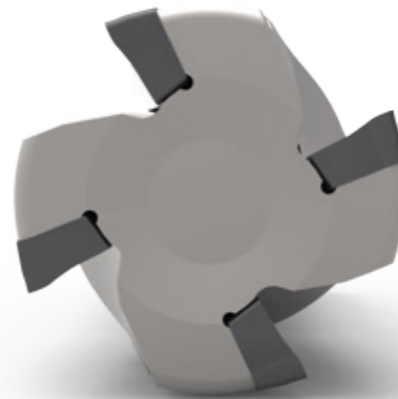

∅40 END MILLS CUTTER,
APKT 16 / 4 TEETH

APKT 060204 PDTR – LT 3000

Material Group	Gr. N°	VDI Group	Material Examples	Hardness	D.O.C [mm]		Feed [mm/tooth]		V _c [m/min]		Suggested Starting Parameters		
					min	max	min	max	min	max	D.O.C	Feed	V _c
Non Alloyed	1	1	C35, Ck45,	125 HB	0.3	5.5	0.04	0.13	190	330	1.3	0.07	250
		2	1020, 1045,	190 HB									220
		3	1060, 28Mn6	250 HB									200
Low Alloyed	2	6	42CrMo4,	180 HB	0.3	5.5	0.03	0.10	150	240	1.3	0.06	200
		4,6	Si50, Ck60,	230 HB									180
		5,7	4140, 4340,	280 HB									150
		8	100Cr06	350 HB									190
													170
High Alloyed	3	10	X40CrMoV5,	220 HB	0.3	3.9	0.03	0.09	90	150	1.0	0.05	130
		10	H13, M42, D3,	280 HB									120
		11	S6-5-2, 12Ni19	320 HB									110
		11		350 HB									80
Austenitic	4	14	304, 316,	180 HB	0.3	5.5	0.03	0.10	190	250	1.3	0.06	220
		14	X5CrNi18-9	240 HB									190
Duplex	5	14	X2CrNi23-4,	290 HB	0.3	3.9	0.03	0.07	70	130	1.0	0.05	100
		14	S31500	310 HB									90
Ferritic & Martensitic	6	12	410, X6Cr17,	200 HB	0.3	5.5	0.03	0.10	150	210	1.3	0.06	190
		13	17-4PH, 430	42 HRc									150
Grey	7	15	GG20, GG40,	150 HB	0.3	5.5	0.04	0.13	150	240	1.3	0.07	200
		15	EN-GJL-250	200 HB									180
		16		250 HB									160
Malleable & Nodular	8	17,19	GG20, GG70,	150 HB	0.3	5.5	0.03	0.11	100	200	1.3	0.06	180
		17,19	50005	200 HB									150
		18,20		250 HB									130
Fe, Ni & Co based	9	31,32	Incoloy 800	240 HB	0.3	3.9	0.03	0.07	25	45	1.0	0.05	32
		33	Inconel 700	250 HB									30
		34	Stellite 21	350 HB									30
Ti based	10	36	TiAl6V4	-	0.3	3.9	0.08	0.07	40	65	1.0	0.05	55
		37	T40	-									30
Steel	11	38	X100 CrMo13,	45 HRc	0.3	1.2	0.06	0.06	40	70	0.7	0.04	60
		38	440C,	50 HRc									55
		38	G-X260NiCr42	55 HRc									60
		40	Ni-Hard 2	400 HB									80
Chilled Cast Iron White Cast Iron	41	41	G-X300CrMo15	55 HRc	0.3	0.5	0.06	0.06	30	60	0.3	0.04	50
													40
Aluminium	12	25	AlSi12	130 HB	0.3	5.5	0.04	0.13	200	400	1.3	0.08	280

SOLID CARBIDE END MILLS

4 FLUTE WITH CORNER RADIUS

LT 4000



PRODUCT RANGE



IMPROVED HEAT DISSIPATION.
DECREASED VIBRATION.
LESS CORNER STRESS.

Lamina Technologies is pleased to announce the addition of a new geometry to our line of high performance solid carbide end mills.

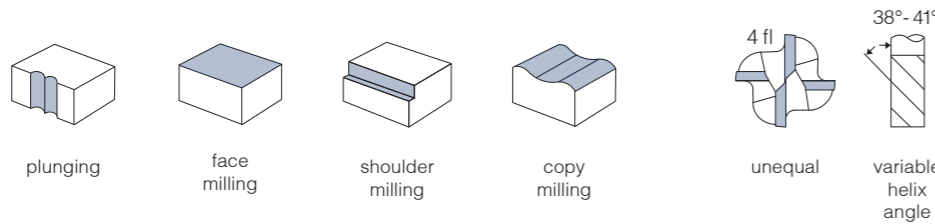
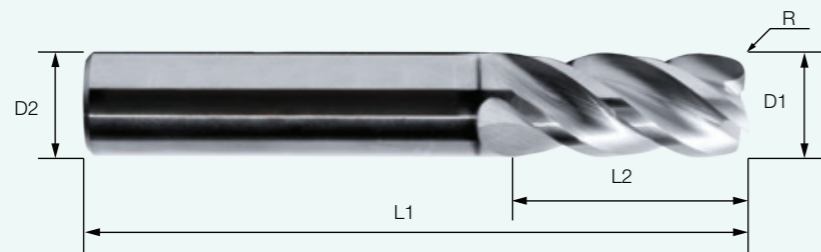

With the addition of a corner radius, our extended solid end mill program provides increased tool life by improved heat dissipation and less corner stress while the unequal pitch prevents vibration improving application.

The corner radius provides the possibility of using our solid end mills in semi-finishing operations, particularly for the mold and die industry.

Corner radius of 0.5, 1.0 and 2.0 available in regular length version and radius 0.5 in long version.

FEATURES

- Unique substrate
- Advanced LT 4000 Multi-Mat™ grade
- Exclusive edge preparation and pre-coating surface treatment
- Breakthrough in materials science
- New, exclusive ultra fine grained coating
- Unequal pitch

MULTI-MAT™

magia

90° 4 FLUTE WITH RADIUS

DESIGNATION	R	D1	D2	L1	L2	CATALOG #
E90 Z4 D03.0(06) L08.0(050)R0.5	0.5	3.0	6	50	8.0	M5003614
E90 Z4 D04.0(06) L11.0(050)R0.5	0.5	4.0	6	50	11.0	M5003615
E90 Z4 D05.0(06) L13.0(050)R0.5	0.5	5.0	6	50	13.0	M5003616
E90 Z4 D06.0(06) L16.0(050)R0.5	0.5	6.0	6	50	16.0	M5003617
E90 Z4 D08.0(08) L20.0(060)R0.5	0.5	8.0	8	60	20.0	M5003618
E90 Z4 D10.0(10) L22.0(072)R0.5	0.5	10.0	10	72	22.0	M5003619
E90 Z4 D12.0(12) L26.0(075)R0.5	0.5	12.0	12	75	26.0	M5003620
E90 Z4 D03.0(06) L08.0(050)R1.0	1.0	3.0	6	50	08.0	M5003623
E90 Z4 D04.0(06) L11.0(050)R1.0	1.0	4.0	6	50	11.0	M5003624
E90 Z4 D05.0(06) L13.0(050)R1.0	1.0	5.0	6	50	13.0	M5003625
E90 Z4 D06.0(06) L16.0(050)R1.0	1.0	6.0	6	50	16.0	M5003626
E90 Z4 D08.0(08) L20.0(060)R1.0	1.0	8.0	8	60	20.0	M5003627
E90 Z4 D10.0(10) L22.0(072)R1.0	1.0	10.0	10	72	22.0	M5003628
E90 Z4 D12.0(12) L26.0(075)R1.0	1.0	12.0	12	75	26.0	M5003629
E90 Z4 D06.0(06) L16.0(050)R2.0	2.0	6.0	6	50	16.0	M5003632
E90 Z4 D08.0(08) L20.0(060)R2.0	2.0	8.0	8	60	20.0	M5003633
E90 Z4 D10.0(10) L22.0(072)R2.0	2.0	10.0	10	72	22.0	M5003634
E90 Z4 D12.0(12) L26.0(075)R2.0	2.0	12.0	12	75	26.0	M5003635

90° 4 FLUTE WITH RADIUS, LONG

DESIGNATION	R	D1	D2	L1	L2	CATALOG #
E90 Z4 D08.0(08) L32.0(090)R0.5	0.5	8.0	8	90	32.0	M5003638
E90 Z4 D10.0(10) L40.0(100)R0.5	0.5	10.0	10	100	40.0	M5003639
E90 Z4 D12.0(12) L48.0(110)R0.5	0.5	12.0	12	110	48.0	M5003640

E90° Z4 with Radius 2.0 | Ø 6, 8, 10, 12 – LT 4000

Material Group	Gr. N°	VDI Group	Material Examples	Hardness	Profiling		Slotting				Vc [m/min]		
					ap	ae	ap	Ø 6	Ø 8	Ø 10	Ø 12	min	max
P Non Alloyed Low Alloyed High Alloyed	1	1	C35, Ck45, 1020, 1045, 1060, 28Mn6	125 HB	1.5xØ	0.5xØ	1.0xØ	0.040	0.055	0.065	0.077	150	200
				190 HB								140	190
				250 HB								120	160
	2	6	42CrMo4, S150, Ck60, 4140, 4340, 100Cr06	180 HB	1.5xØ	0.5xØ	1.0xØ	0.039	0.053	0.063	0.074	120	180
				230 HB								90	130
				280 HB								80	120
				350 HB								60	90
	3	10	X40CrMoV5, H13, M42, D3, S6-S-2, 12Ni19	220 HB	1.5xØ	0.5xØ	1.0xØ	0.033	0.046	0.055	0.064	70	130
				280 HB								65	110
				320 HB								60	90
				350 HB								50	80
M Austenitic	4	14	304, 316, X5CrNi18-9	180 HB	1.5xØ	0.5xØ	1.0xØ	0.028	0.038	0.045	0.053	80	120
				240 HB								70	115
M Duplex	5	14	X2CrNiN23-4, S31500	290 HB	1.5xØ	0.5xØ	1.0xØ	0.021	0.029	0.035	0.040	60	100
				310 HB								60	90
M Ferritic & Martensitic	6	12	410, X6Cr17, 17-4PH, 430	200 HB	1.5xØ	0.5xØ	1.0xØ	0.021	0.029	0.035	0.040	50	90
				42 HRc								30	55
K Grey	7	15	GG20, GG40, EN-GJL-250	150 HB	1.5xØ	0.5xØ	1.0xØ	0.047	0.064	0.076	0.089	140	200
				200 HB								150	190
				250 HB								120	160
K Malleable & Nodular	8	17,19	GG20, GG70, 50005	150 HB	1.5xØ	0.5xØ	1.0xØ	0.040	0.055	0.066	0.077	130	180
				200 HB								110	150
				250 HB								90	130
				-								30	50
S Fe, Ni & Co based	9	31,32	Incoloy 800	240 HB	1.5xØ	0.3xØ	1.0xØ	0.023	0.031	0.037	0.044	30	50
				250 HB								25	45
				350 HB								20	50
				-								30	60
H Steel	11	38	X100 CrMo13, 440C, G-X260NiCr42	45 HRc	1.5xØ	0.3xØ	0.2xØ	0.017	0.023	0.028	0.032	40	60
				50 HRc								35	55
				55 HRc								30	50
				400 HB								35	55
H Chilled Cast Iron	11	40	Ni-Hard 2	400 HB	1.5xØ	0.2xØ	0.1xØ	0.013	0.017	0.021	0.024	30	50
				55 HRc								30	50
NF Aluminium	12	25	AlSi12	130 HB	1.5xØ	0.5xØ	1.0xØ	0.042	0.058	0.069	0.081	160	250

E90° Z4 with Radius 0.5 Long | Ø 8, 10, 12 – LT 4000

Material Group	Gr. N°	VDI Group	Material Examples	Hardness	Profiling		Slotting				Vc [m/min]			
					ap	ae	ap	Ø 8	Ø 10	Ø 12	min	max		
P Non Alloyed Low Alloyed High Alloyed	1	1	C35, Ck45, 1020, 1045, 1060, 28Mn6	125 HB	3.0xØ	0.25xØ	1.0xØ	0.050	0.059	0.070	0.070	150	200	
				190 HB								140	190	
				250 HB								120	160	
	2	6	42CrMo4, S150, Ck60, 4140, 4340, 100Cr06	180 HB	3.0xØ	0.25xØ	1.0xØ	0.044	0.053	0.062	0.062	0.062	120	180
				230 HB									90	130
				280 HB									80	120
				350 HB									60	90
	3	10	X40CrMoV5, H13, M42, D3, S6-S-2, 12Ni19	220 HB	3.0xØ	0.25xØ	0.7xØ	0.035	0.042	0.049	0.049	0.049	70	130
				280 HB									65	110
				320 HB									60	90
				350 HB									50	80
M Austenitic	4	14	304, 316, X5CrNi18-9	180 HB	3.0xØ	0.25xØ	1.0xØ	0.032	0.039	0.045	0.045	80	120	
				240 HB								70	115	
M Duplex	5	14	X2CrNiN23-4, S31500	290 HB	3.0xØ	0.25xØ	1.0xØ	0.025	0.030	0.035	0.035	60	100	
				310 HB								60	90	
M Ferritic & Martensitic	6	12	410, X6Cr17, 17-4PH, 430	200 HB	3.0xØ	0.25xØ	1.0xØ	0.024	0.029	0.033	0.033	50	90	
				42 HRc								30	55	
K Grey	7	15	GG20, GG40, EN-GJL-250	150 HB	3.0xØ	0.25xØ	1.0xØ	0.047	0.056	0.066	0.066	140	200	
				200 HB								150	190	
				250 HB								120	160	
K Malleable & Nodular	8	17,19	GG20, GG70, 50005	150 HB	3.0xØ	0.25xØ	1.0xØ	0.045	0.053	0.063	0.063	130	180	
				200 HB								110	150	
				250 HB								90	130	
				-								30	50	
S Fe, Ni & Co based	9	31,32	Incoloy 800	240 HB	3.0xØ	0.10xØ	1.0xØ	0.020	0.024	0.028	0.028	30	50	
				250 HB								25	45	
				350 HB								20	50	
				-								30	60	
H Steel	11	38	X100 CrMo13, 440C, G-X260NiCr42	45 HRc	3.0xØ	0.10xØ	0.1xØ	0.017	0.021	0.024	0.024	40	60	
				50 HRc								35	55	
				55 HRc								30	50	
				400 HB								35	55	
H Chilled Cast Iron	11	40	Ni-Hard 2	400 HB	3.0xØ	0.10xØ	0.1xØ	0.015	0.018	0.021	0.021	30	50	
				55 HRc								30	50	
NF Aluminium	12	25	AlSi12	130 HB	3.0xØ	0.25xØ	1.0xØ	0.050	0.050	0.070	0.070	160	250	



Lamina Technologies is a Swiss manufacturer of carbide cutting tools specializing in milling and turning inserts made of state-of-the-art sub-micron grades and coatings by our team of specialists in our factory in Switzerland.

With the Multi-Mat™ concept, Lamina Technologies provides products that machine multiple materials with the same insert, thus allowing you to increase flexibility as well as reduce stock of unused and redundant cutting tools, allowing you to reduce the cost of production and increase production efficiency.

- Simplify your process
- Decrease your tooling costs
- Minimize your machining down time
- Increase your production efficiency

Lamina continues its fast pace worldwide expansion and is currently represented in over 32 countries.

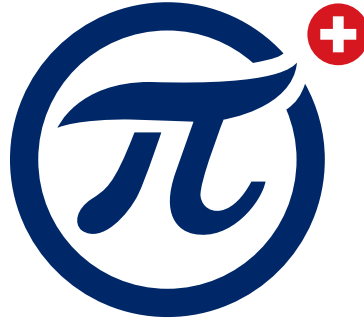

LAMINA TECHNOLOGIES

HEADQUARTERS

Lamina Technologies SA Switzerland

Rue Pythagore, 2
1400 Yverdon-les-Bains
Switzerland
T./F. +41 (0)24 423 55 55
info@lamina-tech.ch
www.lamina-tech.ch

SUBSIDIARIES

Lamina Technologies Deutschland GmbH

Athenslebener Weg 33
39418 Staßfurt
Germany
T. +49 (3925) 329 277
F. +49 (3925) 329 278
info@lamina-tech.de
www.lamina-tech.ch

Lamina Technologies SA France

15 Rue Bernard Palissy
Jeantet STJ
25300 Granges Narboz
France
T./F. +33 381 49 67 30
info@lamina-tech.fr
www.lamina-tech.ch

Lamina Technologies do Brasil Ltda.

Avenida Macuco, 726 Cj. 1603/1604
04523-001 Moema
São Paulo - SP
Brazil
T. +55 11 2344 7890
F. +55 11 2344 7888
info@laminabrasil.com.br
www.laminabrasil.com.br

Lamina Technologii LLC Russia

Building 21
Zarayskaya str.
109428 Moscow
Russia
T./F. +7 499 653 93 56
info@lamina-russia.ru
www.lamina-russia.ru

Lamina Teknolojileri Kesici Takımlar Ltd ti.

Kuştepe Mahallesi Mesut
Cemil Sokak 22/B
34381 Şişli, İstanbul
Turkey
T. +90 212 292 09 21
F. +90 212 292 59 51
info@laminatknolojileri.com.tr
www.laminatknolojileri.com.tr

Lamina Technologies China

Room 202, Building B
668 Hengfeng Road, Jing An Dist.
200070 Shanghai
China
T. +86 21 2287 6501
info@lamina-tech.ch
www.lamina-tech.ch